

**End Elevation**

Scale  $\frac{1}{4}" = 1'-0"$

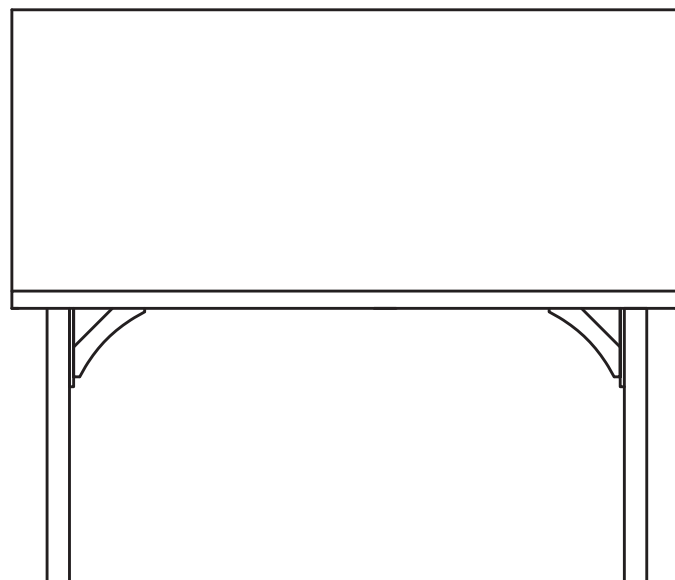

**Side Elevation**

Scale  $\frac{1}{4}" = 1'-0"$

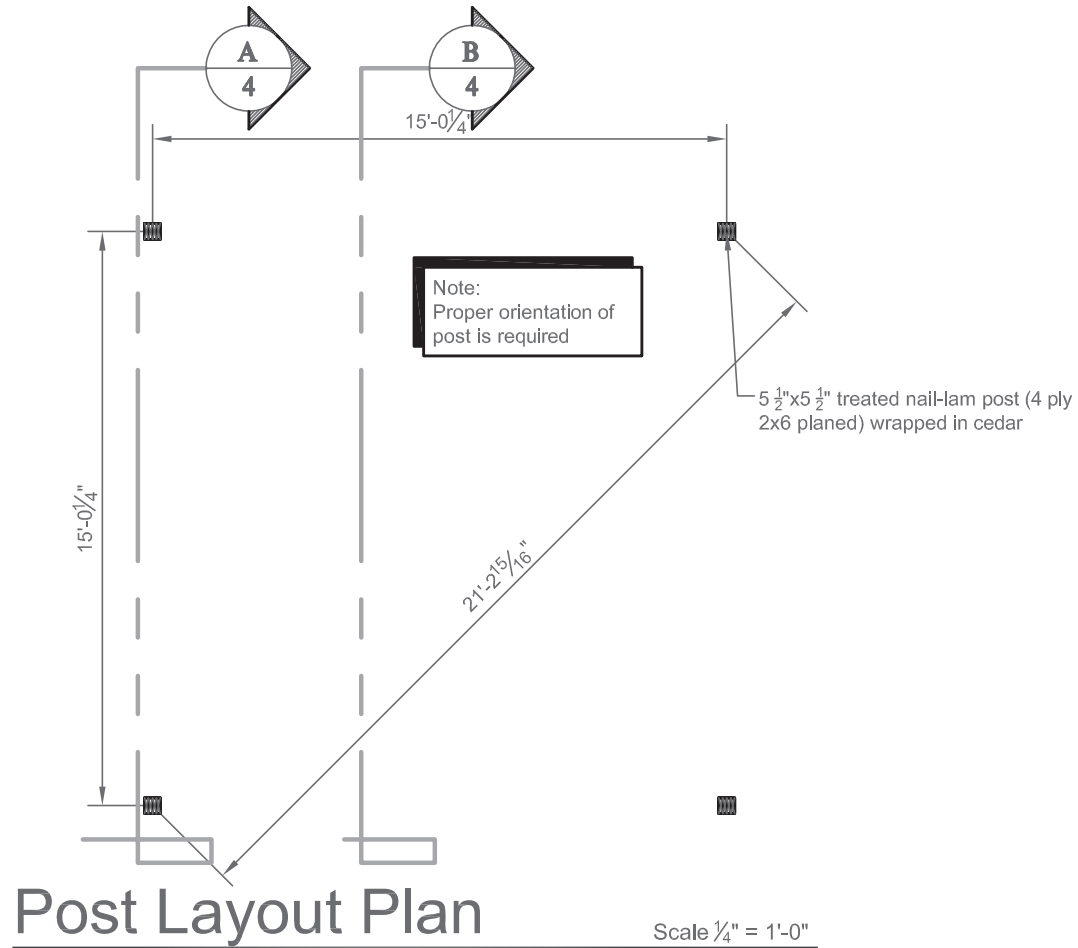

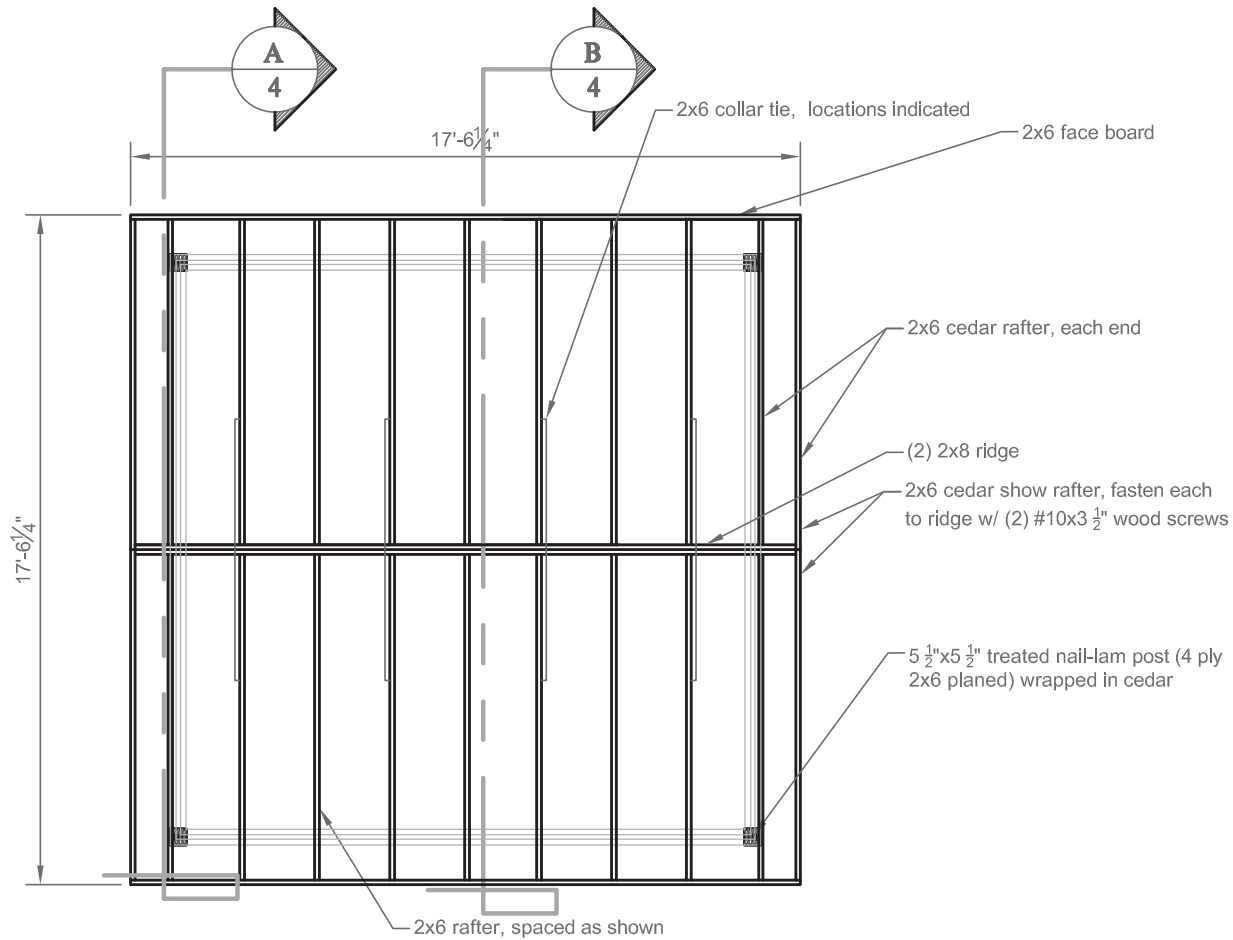

# Roof Framing Plan

Scale 1/4" = 1'-0"

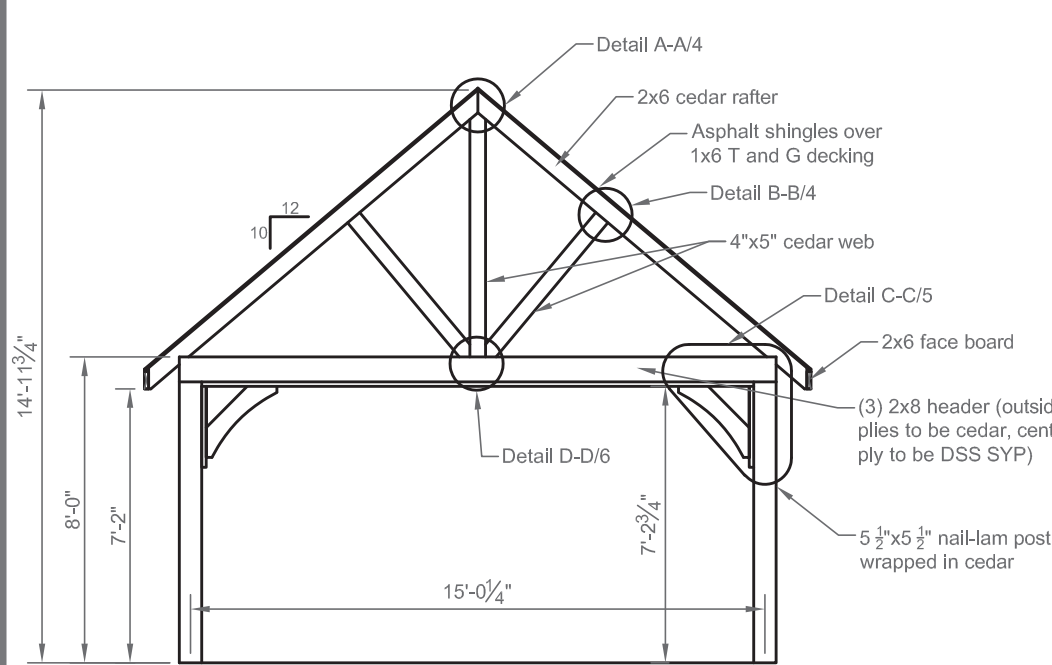

**Cross Section A/4**

Scale 1/4" = 1'-0"

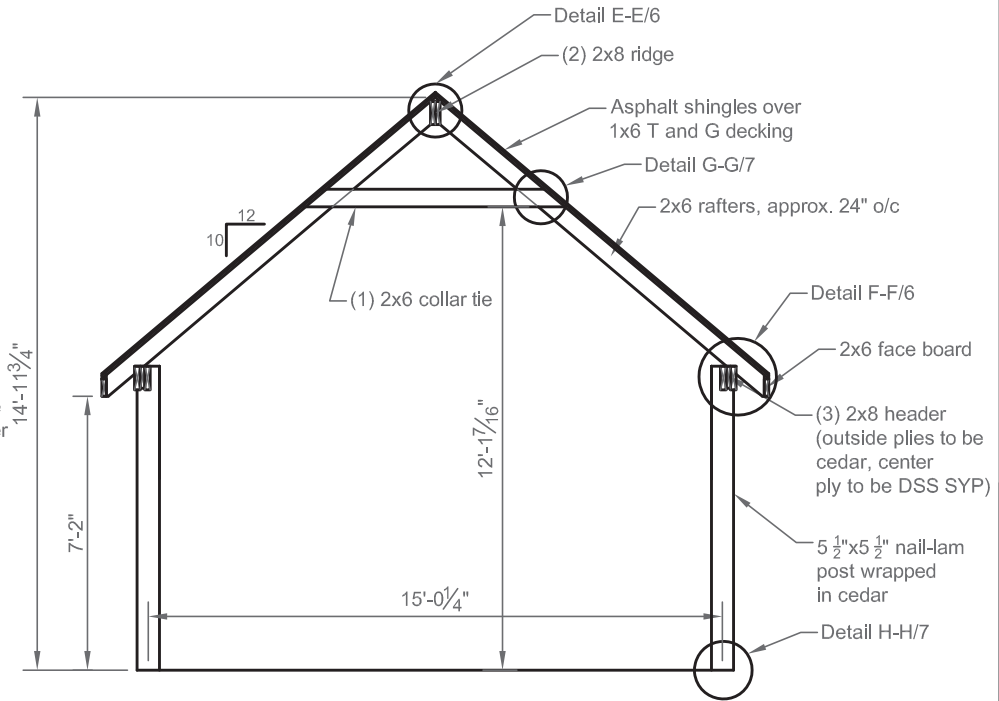

**Cross Section B/4**

Scale 1/4" = 1'-0"

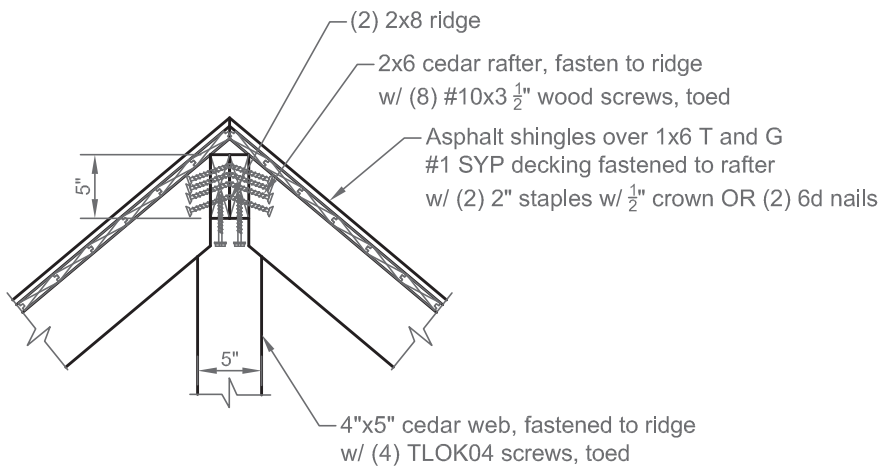

**Detail A-A/4**

Scale 1" = 1'-0"

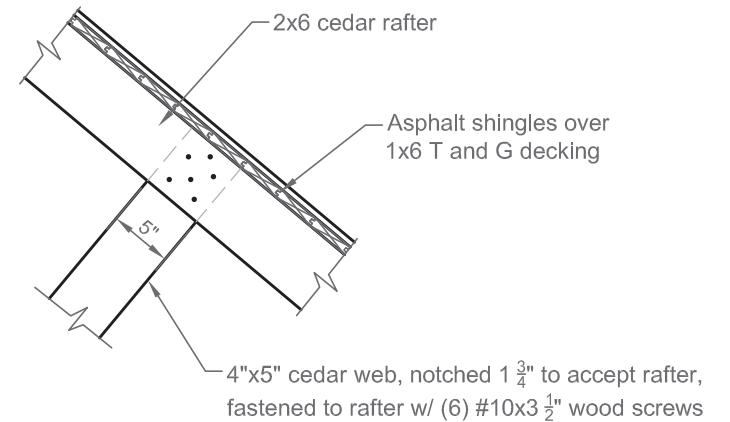

**Detail B-B/4**

Scale 1" = 1'-0"